

DTR Series

Submersible Pumps | Sewage Grinder Pumps



Made in Italy
by Pentax Pumps

Application

The DTR Series are Sewage / wastewater submersible pumps for domestic and commercial applications with open impeller design. The treated stainless steel grinder is capable of pumping sewage which contains textile or filamentous fibres and suspended solids.

Specification

- Pump body: Cast iron
- Impeller: Brass
- Mechanical seal: Double seal with oil barrier: silicon carbide on pump side, sealing ring on motor side
- Motor shaft: Stainless steel AISI 430
- Depth of immersion: Max 5m
- Grinder: Treated stainless steel
- Liquid temperature: 0-40 °C
- Cable: HO7 RN8F, 10m
- A: Float switch



Impeller



Grinder

- 2 poles induction motor: 3-400V - 50 Hz
- 1-230V - 50 Hz (with thermal overload protection)
- Insulation class: F
- Protection degree: IPX8

Technical Data

Model	Volts	Power (kW)	Amps (A)	Max. FLOW (L/min)	Max. HEAD (m)	Outlet (mm)	Cable Length (m)
DTR101-1A	240	1.2	5.3	220	19	40	10
DTR101-3	415	1.2	2.2	220	19	40	10

Model	Q (m³/h - l/min)						
	0	3	6	9	12	13.2	
	0	50	100	150	200	220	
	H (m)						
1 Phase	3 Phase						
DTR101-1A	DTR101-3	19	17.1	14.8	11.9	7.8	7.8

Performance

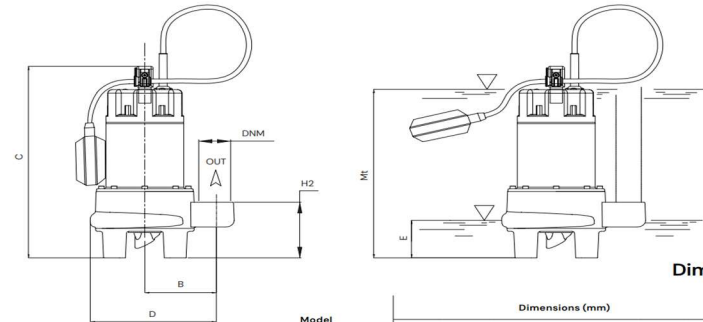
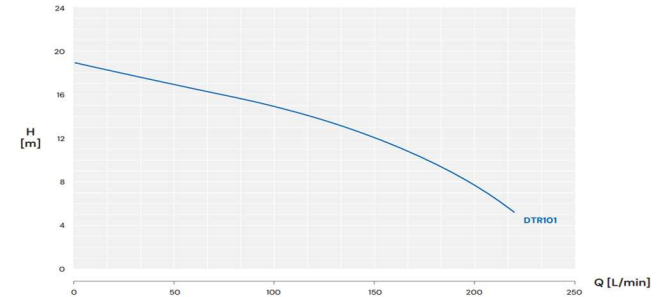

Dimensions

Model	Dimensions (mm)							Kg
	B	C	D	E	H2	Mt	DNM	
DTR101	105	359	218.5	70	104.5	313	32	12.0

Model Range

Model	Description
DTR101-1A	Hyjet 1200 Watt 240V 220 L/min 19m Head Sewage Grinder Submersible Pump - with Float Switch
DTR101-1	Hyjet 1200 Watt 240V 220 L/min 19m Head Sewage Grinder Submersible Pump - Manual
DTR101-3	Hyjet 1200 Watt 415V 3 Phase 220 L/min 19m Head Sewage Grinder Submersible Pump - Manual

Commercial Plumbing & Fire Supplies

Site Address

6A Kelly Court,
Springvale, VIC 3171

Postal Address

6A Kelly Court,
Springvale, VIC 3171

Contact Details

P: 03 9791 7500
E: sale@cpfs.net.au

