



# **STAINLESS STEEL FIRE BOOSTER VALVE**

**Certified to AS/NZS 2419.3  
Global-Mark ID 109076**



- **High Strength, Premium Quality Dual Booster Assembly**
- **Stainless Steel Booster Body, Inlet Connection, Seating Disc, Spring, Drain Valve & Pressure Gauge**
- **High Corrosion Resistance**
- **Oil Filled Pressure Gauge**
- **Long Service Life**
- **Comes with Pressure Gauge, Drain Valve, Dust Cap & Chain**
- **Class PN 21 High pressure booster valve**
- **Fully Tested and Approved to AS2419.3-2012**

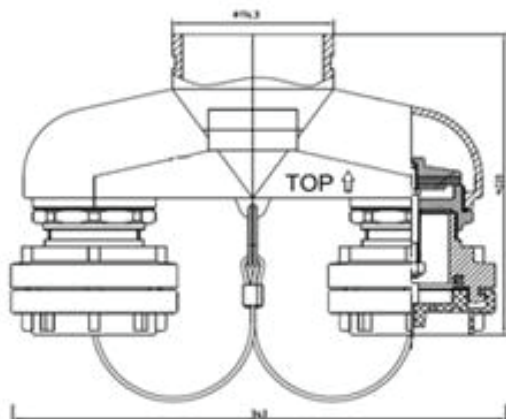
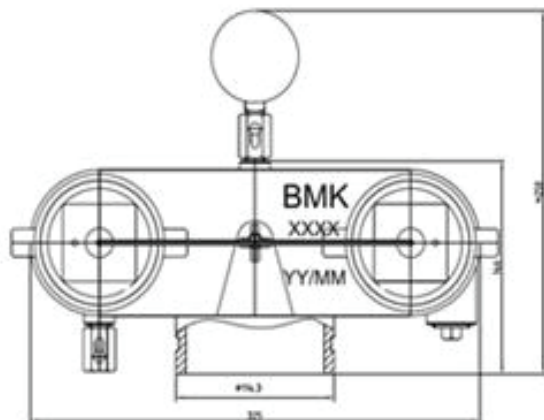

Stock Code	Body Type	Inlet Connections	Height	Width	Weight
BVBACKENTBI	Dual Booster -Rear outlet	65mm BI	250mm	325mm	6.7kg
BVBACKENTQRT	Dual Booster -Rear outlet	65mm QRT	250mm	325mm	7.6kg
BVBACKENTSART	Dual Booster -Rear outlet	65mm SART	250mm	325mm	7.8kg
BVBACKENTSTZ or /NSW	Dual Booster -Rear outlet	65mm STORZ	250mm	343mm	7.2kg
BVBOTTOMENTBI	Dual Booster -Bottom outlet	65mm BI	250mm	325mm	7.4kg
BVBOTTOMENTQRT	Dual Booster -Bottom outlet	65mm QRT	250mm	325mm	8.3kg
BVBOTTOMENTSART	Dual Booster -Bottom outlet	65mm SART	250mm	325mm	8.5kg
BVBOTTOMENTSTZ or /NSW	Dual Booster -Bottom outlet	65mm STORZ	250mm	343mm	7.9kg
Material					
• Booster Body	Stainless Steel Grade 304				
• Inlet Connection	Stainless Steel Grade 304/Forged Alloy for Storz model				
• Pressure Gauge	Stainless Steel Grade 304 with oil filled				
• Drain Valve	Stainless Steel Grade 304				
• Disc Facing	NBR Rubber				
• Blank Cap	UV Stabilized Plastic				
Working Pressure	2,100 kPa				
Maximum Working Pressure	2,650 kPa				
Onsite Test Pressure	3,150 kPa				