

# REMOVABLE DRY DIAL WOLTMANN WATER METER

Model LXLGC/LD-50-500E/C with pulser

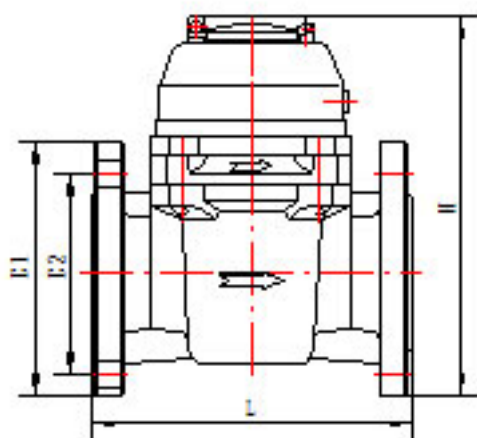

## Application

Totalise the total volume of cold (hot) water passing through the pipeline. This type of water meter can also be used for remote reading transmission system as it is equipped with a built-in sensor.

## Special Features

- Measuring mechanism has three different types
- Removable element structure for ease of installation and maintenance
- Register for universal use within this range and detachable without removing meter from the pipeline
- Dry dial magnetic drive sensitive action with small pressure loss
- Roller counter with large central pointer type for easy reading
- Vacuum sealed water resistant register to prevent condensation
- Manufactured from the highest quality materials for reliability and prevention of corrosion

## Maximum Permissible Error

From transitional flow up to maximum flow both inclusive:

- $\pm 2\%$  for cold water
- $\pm 3\%$  for hot water

From minimum flow inclusive up to transitional flow:  $\pm 5\%$

Technical data conforms to ISO 4064 Class B standards

Flow Error Curve

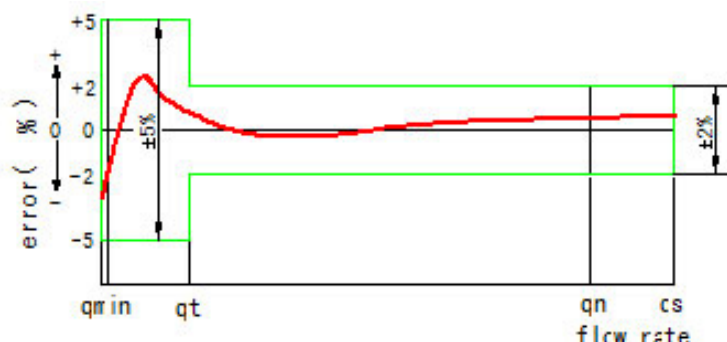

Pressure Loss Error Curve

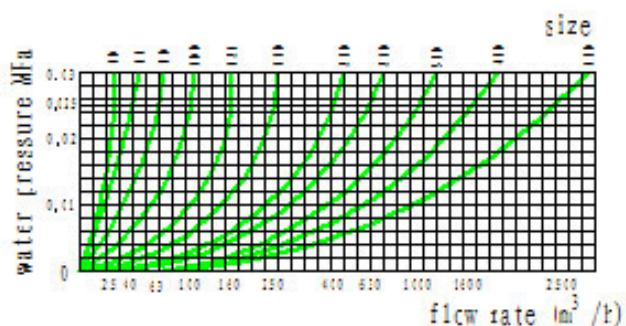

## Technical Data

### Dimensions and Weights

Size	Length	Height	Outer Diameter	Bolt Circle Diameter	Connecting Bolt (n-Md)	Weight (kg)
50	200	247	150	114	4-M16	10
65	200	260	165	127	4-M16	13.5
80	225	265	185	146	4-M16	15.5
100	250	272	215	178	4-M16	18.5
125	250	295	255	210	8-M16	25
150	300	302	280	235	8-M16	28
200	350	359	335	292	8-M16	48
250	450	47	405	356	8-M20	79
300	500	492	455	406	12-M20	93
350	500	592	525	470	12-M24	125
400	600	631	580	521	12-M24	197
500	800	740	705	641	16-M24	304

### Main Technical Specifications

Size	Class	Max Flow	Nominal Flow	Transitional Flow	Min Flow	Min Reading	Max Reading
mm		m <sup>3</sup> /h	m <sup>3</sup> /h	m <sup>3</sup> /h	m <sup>3</sup> /h	m <sup>3</sup>	m <sup>3</sup>
50	B	30	15	3.0	0.45	0.001	999999
65	B	50	25	5.0	0.75	0.001	999999
80	B	80	40	8.0	1.2	0.001	999999
100	B	120	60	12	1.8	0.001	999999
125	B	200	100	20	3.0	0.001	999999
150	B	300	150	30	4.5	0.01	9999999
200	B	500	250	50	7.5	0.01	9999999
250	B	800	400	80	12	0.01	9999999
300	B	1200	600	120	18	0.01	9999999
350	B	1600	800	160	24	0.1	99999999
400	B	2000	1000	200	30	0.1	99999999
500	B	3000	1500	300	45	0.1	99999999

Recycled Rain Pty Ltd  
6A, Kelly Court, Springvale,  
VIC 3171

T +61 3 9791 7500

F +61 3 9791 7500

M +61 404 990 704

sales@cpfs.net.au

ABN 669 699 43813

Note: Innovation for better quality and technology progress may be made without pre-notification

### About Recycled Rain

Recycled Rain is one of Australia's leading gas and water measurement and control distributors. Meters of the LianLi brand perform strictly as per ISO 4064 Class B, EEC Standard 75/33/EEC and National Standard GB/T778. LianLi's management systems are also certified to ISO 9001 and ISO 14001, the international standards for Quality and Environmental Management.